



HOT BRIQUETTED IRON (HBI)

QUALITY ASSESSMENT GUIDE

Disclaimer:

The information presented in this guide is intended as general information only and should not be relied upon in relation to any specific application. Those making use thereof or relying thereon assume all risks and liability arising from such use or reliance.

HOT BRIQUETTED IRON (HBI) - QUALITY ASSESSMENT GUIDE

Contents

1. Introduction	3
2. Sampling and sample preparation of HBI	3
2.1 General.....	3
3. Physical Quality of HBI	5
3.1 General.....	5
3.2 Apparent Density	6
3.3 Briquette Strength	7
4. Chemical Composition	8
4.1 Introduction	8
4.2 Sample preparation	9
4.3 Total Iron.....	9
4.4 Metallic Iron.....	9
4.5 Carbon / Sulphur	10
4.6 Cementite (Fe ₃ C)	10
4.7 Phosphorus	10
4.8 Gangue by X-ray fluorescence	10
5 Reactivity.....	11
6. Other physico-chemical tests.....	11
Annex 1: Selected Definitions and Nomenclature.....	13

Copyright Notice: this document may not be reproduced in whole or in part without the express written permission of the International Iron Metallics Association.

1. Introduction

This guide is an update of the 2011 guide published by the Hot Briquetted Iron Association, one of IIMA's founding associations. Its purpose is to provide guidelines on assessment of product quality for producers, consumers and others involved in the handling, shipping, and storage of Hot Briquetted Iron.

For the purposes of this guide, the definition of Hot Briquetted Iron (or HBI as it is commonly known) is that used by the International Maritime Organisation in its International Maritime Solid Bulk Cargoes Code (IMSBC Code) in which HBI is designated **Direct Reduced Iron (A) - Briquettes hot-moulded**. The schedule for Direct Reduced Iron (A) gives the following description):

Direct reduced iron (A) is a metallic grey material, moulded in a briquette form, emanating from a densification process whereby the direct reduced iron (DRI) feed material is moulded at a temperature greater than 650°C and has a density greater than 5,000 kg/m³. Fines and small particles (under 6.35 mm) shall not exceed 5% by weight.

This guide is intended for HBI which conforms to this quality description which is the basis on which HBI is traded and shipped globally. It is possible that other grades of HBI may be developed in the future in which case this guide will be reviewed for applicability to such grades. This guide should not be assumed to be applicable to Direct Reduced Iron, Sponge Iron, DRI Fines, etc., even though this may be the case in some respects, e.g. with respect to sampling and sample preparation.

If you require further information, please contact IIMA (info@metallics.org).

2. Sampling and sample preparation of HBI

2.1 General

Samples for analysis of HBI should be drawn and prepared in accordance with the following international standard or equivalent national standard: **ISO 10835: 2007 Direct Reduced Iron and hot briquetted iron – Sampling and sample preparation** (last reviewed and confirmed in 2016). However, should it not be possible for sampling and sample preparation to be performed in accordance with such standard, sampling and sample preparation should to the extent practicable be performed in accordance with other relevant and applicable standards. In such circumstances, it is strongly recommended that the contractual parties first agree upon and document the sampling and sample preparation standards and procedures to be followed.

ISO 10835:2007 gives

1. the underlying theory,
2. the basic principles for sampling and preparation of samples, and
3. the basic requirements for the design, installation and operation of sampling systems,

for mechanical sampling, manual sampling and preparation of samples taken from a lot under transfer, to determine the chemical composition, moisture content and physical properties of the lot. The methods specified in this International Standard are applicable to both the loading and discharging of direct reduced iron (DRI) and hot briquetted iron (HBI), by means of belt conveyors and other ore handling equipment to which a mechanical sampler may be installed or where

stopped-belt sampling may safely be conducted. In this International Standard, DRI includes both reduced pellets and reduced lump ores.

The following is a shortened and simplified first overview of sampling procedures. Regarding further details please refer to ISO10835!

2.2 Obtaining sample increments

Sampling should normally be done by cutting a complete cross-section of the HBI stream at a transfer point while a lot is being conveyed to or from the ship, stockpile, or container, using a mechanical sample cutter. The cutter aperture of the primary sampler shall be at least three times the longest dimension of the HBI. This requires a cutter with an effective aperture of at least 300 mm (~1 foot).



Figure 1: Surveyors collecting increments using “stopped belt sampling” (images courtesy of Marine Inspection, LLC)

Table for Estimating Required Number of Increments				
Mass of lot (1000 t)		Number of primary increments (n)		
Over	Up to	Quality Variation		
		Large	Medium	Small
70	100	180	90	45
45	70	160	80	40
30	45	140	70	35
15	30	120	60	30
0	15	100	50	25

Note that *n* may be increased or decreased to alter the sampling precision.

Figure 2: HBI Sampling Increments (Reference: ISO 10835 Table 3)

Increments may also be taken by “stopped-belt sampling” (see Figure 1 above). The conveyor has to be shut down to sample manually and the location and procedure must be well defined in advance to ensure the safety of personnel. A cut is made to obtain material from across the full width of the belt, using a shovel and broom to collect fines. It is not recommended to sample from piles since obtaining a completely representative sample is difficult to achieve.

The number of sample increments will depend on the size of the shipment, the quality variation and the desired sampling precision. HBI is normally shipped in vessels in the range 15,000 to 40,000 tonnes. The number of increments can be estimated from the table shown in Figure 2 above.

2.3 Sampling for particle size distribution

Sampling for analysis of particle size distribution may be performed in the field either during vessel discharge or following re-load to conveyor belts for transport to the final customer. Typically, these are collected, photographed, and presented to the client along with size fraction percentage data and graphs, in order to substantiate cargo quality guarantees by the supplier. Suitable sub-sample size fraction increments are: +37.5mm, +25mm, +19mm, +12.5mm, +9.5mm, +6.3mm, +4.0mm, and minus 4.0mm.



*Figure 3: Screen Size Testing
(images courtesy of Marine Inspection, LLC)*

2.4 Sample preparation for chemical analysis

- The sample should be crushed to -12.5 mm (- ½ inch) in a primary jaw crusher.
- Homogenize and riffle out 1/4 of the sample (or as appropriate to reduce sample mass).
- Crush this further to -2 mm in a secondary jaw crusher.
- Homogenize and riffle out 200 to 500 g of material.
- Pulverize this sub-sample to 95% passing -150 µm for analysis. Precautions should be taken at this step to ensure that excessive heat is not generated in the sample which could change the chemical composition [temperatures less than 60°C (140°F) are recommended], e.g. minimize grinding time, grind in small batches.

3. Physical Quality of HBI

3.1 General

The physical quality of an HBI briquette is mainly determined by its apparent density and strength. The water absorption may also be measured (although this is less frequently used). These properties and the relevant test methods are described in ISO standards. These are:

ISO 15968 - direct reduced iron - determination of apparent density and water absorption of hot briquetted iron (HBI).

ISO 15967 - direct reduced iron - determination of tumble and abrasion indices of hot briquetted iron (HBI).

HBI plants currently in production also use several other test methods to determine and control the quality of their product.

3.2 Apparent Density

ISO 15968 – direct reduced iron – determination of apparent density and water absorption of hot briquetted iron (HBI).

In general determination of apparent density is carried out in accordance with the Archimedes principle which states that the apparent weight of an object immersed in a liquid decreases by an amount equal to the weight of the volume of the liquid that it displaces. Since 1 ml of water has a mass almost exactly equal to 1 g, if the object is immersed in water, the difference between the two masses (in grams) will equal (almost exactly) the volume (in ml) of the object weighed. Knowing the mass and the volume of an object allows us to calculate the density.

However, preparation of the test sample is of special importance in the case of HBI. This differs from the well-known Archimedes method for solid and non-porous test pieces in that the remaining open pores have to be soaked in water before determining the apparent density. The main steps according to ISO 15968 are:

- Dry and weigh
- Soak, surface dry and weigh
- Archimedes test (wire basket or wire suspension)

The results determined in this procedure are:

Apparent density ρ_a (basket method):

$$\rho_a = m_1 / (m_4 - m_3)$$

Apparent Density ρ_a (wire suspension method)

$$\rho_a = m_1 / m_4$$

Water Absorption

$$\alpha = (m_2 - m_1) * 100 / m_1$$

Where:

- m_1 is the mass in air, in grams, of the dried briquettes
- m_2 is the mass in air, in grams, of the surface-dried, soaked briquettes
- m_3 is the apparent mass in water, in grams, of the wire suspension basket. This is equivalent to the “apparent volume” of the basket. In the case of the wire suspension method, mass m_3 is negligible
- m_4 is the apparent mass in water, in grams, of the soaked briquettes. This is equivalent to the “apparent volume” of the briquettes

Further details concerning the relevant procedures are described in the ISO standard ISO 15968. Figure 1 below is based on a diagram in this standard and illustrates the determination of the apparent density of briquettes in a water bath. As far as is known, all operating HBI plants utilize this procedure for the determination of briquette density.

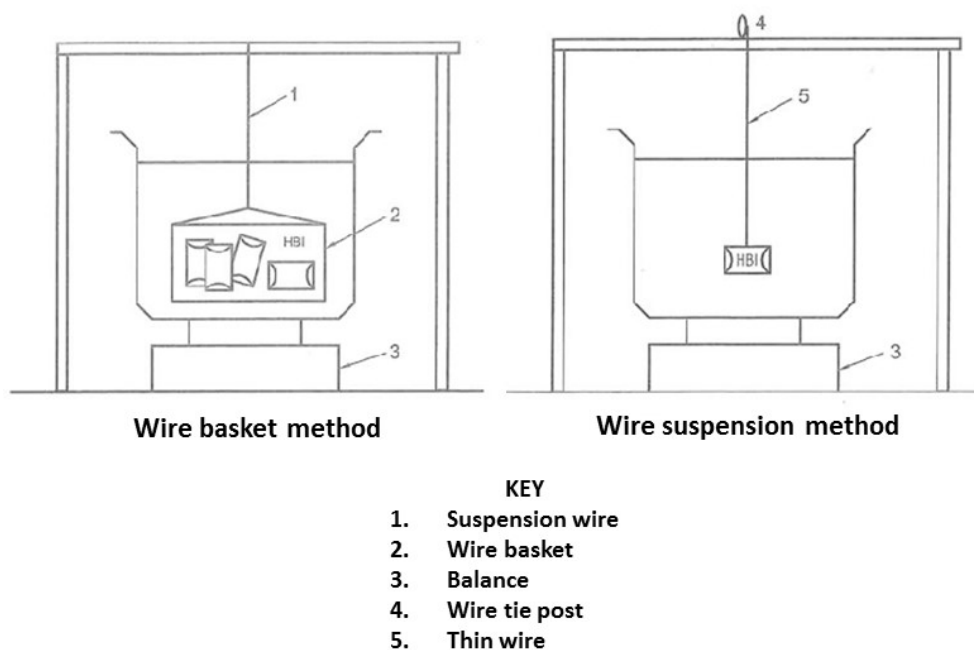

Figure 4: Examples of apparent density apparatus

3.3 Briquette Strength

There are different options for the determination of briquette strength. In each case the intention is to simulate the briquette breakage and fines loss to be expected during transport and handling of the product.

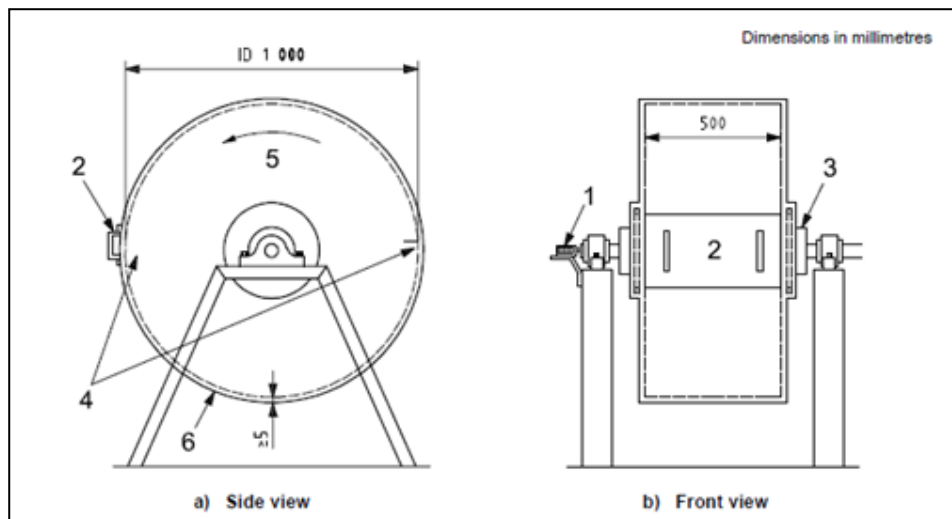

Figure 5: The tumble drum for determination of the tumble and abrasion index (ISO 15967)

Key to Figure 5	
1	Revolution counter
2	Door with handle
3	Stub axle (no through shaft)
4	Two lifters (50 x 50 x 5)
5	Direction of rotation
6	Plate
ID	Internal diameter



Figure 6: The tumble drum for determination of the tumble and abrasion index (ear protection required!)

An ISO standardized procedure is described in: **ISO 15967 - direct reduced iron - determination of tumble and abrasion indices of hot briquetted iron (HBI)**. According to this standard, an abrasion drum with a diameter of 1,000 mm and a width of 500 mm with two lifters is used. Similar equipment is also used to test iron ore pellets and is illustrated in Figures 5 and 6 above. The rotational speed is defined with 25 rpm. The test is finalized after 200 revolutions.

According to ISO 15967 the following data are recorded or indicated:

- Tumble index: Percentage of the remaining material > 6.3 mm after 200 revolutions of the drum
- Abrasion index: Material < 0.5 mm in percent after 200 revolutions

ISO 15967 does not contain a list of definitions, but includes a cross reference to another standard, **ISO: 11323 - iron ore and direct reduced iron - vocabulary**. Relevant definitions are included in Annex 1 to this guide.

It should be noted that a number of HBI plants have developed and apply procedures for determination of briquette strength which deviate from ISO 15967. These can in principle be divided into two groups:

1 Tumble drum test

Here, a drum as described above is usually used with the same or similar specifications for performing the “tumbling”. However, additional or different screen cuts are utilized.

2 Drop test

These are non-standardized drop tests, varying from one plant to the other, with different drop heights and number of drops. Results are again recorded and documented on the basis of a screen analysis of the material after testing. For further information about such tests, please refer to the relevant information provided by individual HBI plants.

4. Chemical Composition

4.1 Introduction

The chemical composition of HBI can vary depending on its origin: the iron ore used to produce HBI has the largest impact, but other factors such as the process technology can also influence its

chemistry. This section presents the ISO Standards and internationally recognized testing procedures that, when properly applied, define the HBI composition as a manufactured product.

The chemical composition of interest to the consumer of HBI include iron (total iron, metallic iron), carbon, sulphur, phosphorus and gangue (primarily CaO, SiO₂, MgO and Al₂O₃) as they will impact how the HBI is melted into subsequent product.



Figure 7: Chemical analysis laboratory

4.2 Sample preparation

Reference: ISO 14284:1996, Steel and iron - Sampling and preparation of samples for the determination of chemical composition.

A representative sample (as defined in section 2) of the HBI lot is further prepared for chemical analysis by grinding and splitting down to a size suitable for chemical analysis. HBI is a solid, non-homogeneous manufactured product so there is an inherent variability within a lot; careful sampling and sample preparation are critical to maintaining statistical representation necessary to the validity of the reported analyses. In addition, improper sample preparation techniques can alter the sample, leading to false results – for example, excessive heating of the sample during grinding will re-oxidize the metallic iron to iron oxide.

4.3 Total Iron

References:

- **ISO 2597-1:2006, Iron ores – determination of total iron content – Part 1: Titrimetric method after tin (II) chloride reduction**
- **ASTM E246-10 (2015), Standard Test Methods for Determination of Iron in Iron Ores and Related Materials by Dichromate Titration**

These test methods specify titrimetric methods for determination of total iron in iron ore, but are commonly used for HBI as well. The ISO standard specifies a maximum iron content of 72% whereas the ASTM standard goes up to 95%.

Determination of total iron by XRF is commonly used but is not currently a standard.

4.4 Metallic Iron

References:

- **ISO 16878: 2016, Determination of metallic iron – Iron (III) chloride titrimetric method**
- **ISO 5416:2006, Direct reduced iron – determination of metallic iron – Bromine-methanol titrimetric method**

Both test methods specify titrimetric methods for determination of the mass fraction of metallic iron in reduced iron ores such as HBI and DRI. The Ferric Chloride method is applicable to mass fraction of metallic iron range 57.5-90.5%, but is reliably used in higher range.

The bromine methanol method is applicable to a concentration range of 15% to 95% of mass fraction of metallic iron. The bromine methanol method is not recommended due to the hazards associated with bromine methanol and waste products, but it is useful for precision analysis on claims or clarification issues.

Determination of metallic iron by XRF and XRD is not recommended at this time and should only be considered as semi-quantitative.

4.5 Carbon / Sulphur

References:

- **ISO 15350:2000 Steel and iron -- Determination of total carbon and sulphur content -- Infrared absorption method after combustion in an induction furnace (routine method)**
- **ISO 9686:2006 Direct reduced iron - Determination of carbon and/or sulphur - High frequency combustion method with infrared measurement**

In the IR combustion method, the sample is burned in an oxygen atmosphere in an induction furnace. The carbon in the sample is oxidized to carbon dioxide (CO₂) while the sulphur is converted to sulphur dioxide (SO₂). Both CO₂ and SO₂ are then measured by infrared detectors. Several equipment manufacturers supply dedicated equipment for carbon / sulphur determination. HBI samples must be in powder form and is of small size; sample uniformity is critical and the test is often performed in replicates.

4.6 Cementite (Fe₃C)

There are no standards for the direct determination of Cementite. It is possible to estimate the amount of cementite in HBI by subtracting the free carbon measured using ISO 10719:2016 from the total carbon measured using ISO 15350:2000 (see section 4.5 above). The former standard is developed for cast iron and specifies a maximum of 3% carbon. Cementite can also be estimated by X-ray diffraction (XRD) but this method is considered semi-quantitative.

4.7 Phosphorus

References:

- **ISO 4687-1:1992 Iron ores -- Determination of phosphorus content -- Part 1: Molybdenum blue spectrophotometric method**
- **ISO 9516-1:2003 Iron ores -- Determination of various elements by X-ray fluorescence spectrometry -- Part 1: Comprehensive procedure**

Both methods were developed for iron ore but apply also to HBI. The X-ray fluorescence method is commonly used for routine analysis but the accuracy depends on the quality of the calibration curves. The spectrophotometric method is used to determine phosphorus when analyzing unknown samples.

4.8 Gangue by X-ray fluorescence

Reference: **ISO 9516-1:2003 Iron ores -- Determination of various elements by X-ray fluorescence spectrometry -- Part 1: Comprehensive procedure**

Analysis of all gangue components in HBI - such as CaO, SiO₂, MgO and Al₂O₃ - is performed primarily using the x-ray fluorescence (XRF) method developed for iron ore. Various other methods such as titration, atomic absorption or Inductively coupled plasma also exist, but are becoming obsolete.

ISO committees are working on a simplified method (ISO 9516-2) and procedures for internal standards (ISO 9516-3) but they are not finalized at this time.

5 Reactivity

HBI is produced by compacting Directed Reduced Iron (DRI) in a roller press at elevated temperature ($> 650^{\circ}\text{C}$). This is done to reduce the reactivity of the DRI and to minimize yield loss in the form of fines during shipping, handling and storage.

DRI reactivity consists of 2 main reactions: oxidation and hydrogen generation. Both reactions are accelerated by the porous structure of DRI (i.e. very high surface area):

- **Oxidation** is the reaction of iron metal with oxygen, according to $2\text{Fe} + 3/2 \text{O}_2 = \text{Fe}_2\text{O}_3$ (Reaction 1). This reaction generates heat which may not dissipate fast enough in DRI stored in bulk, resulting in localized hot spots. As the temperature rises, the reaction accelerates until no oxygen is present.
- **Hydrogen generation** happens when water dissociates in contact with DRI, according to the reaction $\text{Fe} + 2\text{H}_2\text{O} = \text{Fe}(\text{OH})_2 + \text{H}_2$ (Reaction 2). This reaction is endothermic and slow at room temperature, but accelerates with increased temperature, such as when water is in contact with hot DRI. In the presence of a flame, sufficient quantities of hydrogen will burn or explode. The described reaction is even more pronounced and critical when it comes to contact with seawater.

Depending on the conditions, both reactions can happen simultaneously, where oxygen is both consumed and generated, and hydrogen is produced. Reaction 1 raises the temperature while Reaction 2 cools the DRI.

Hot briquetting reduces available inner surface and porosity. At an apparent density of 5.0 g/cm^3 or higher, the IMO in effect deems the reactivity to be sufficiently reduced for safe shipment of HBI as per the IMSBC Code schedule for DRI (A). The remaining porosity in HBI is mostly a function of pressing force and temperature and is lower than DRI. Because of the drastic reduction in the exposed surface area, the kinetic rate of the chemical reactions above is reduced significantly, making HBI much less reactive than DRI.

There are currently no standard methods for testing HBI reactivity specifically. Most of the test protocols were developed for DRI but have not been standardized by ISO or other organizations. The more common are the Nagel tests and the reactivity tests developed by technology providers Midrex and Tenova/EnergIron.

6. Other physico-chemical tests

In the IMSBC Code (see section 1 above) the International Maritime Organisation (IMO) defines the following hazards applicable to Materials Hazardous only in Bulk (MHB):

Chemical Hazard	Notational Reference
Combustible solids	CB
Self-heating solids	SH
Solids that evolve flammable gas when wet	WF
Solids that evolve toxic gas when wet	WT
Toxic solids	TX
Corrosive solids	CR
Other hazards	OH

A material must be classified as MHB if the material possesses one or more of these chemical hazards. When a test method is prescribed in the Code, representative samples of the cargo to be carried must be used for testing, samples to be taken 200 to 360 mm inward from the surface at 3 m intervals over the length of a stockpile.

The IMO requires testing for these hazards in accordance with the United Nations publication "Recommendations on the TRANSPORT OF DANGEROUS GOODS: Manual of Tests and Criteria"¹. In some cases, these tests have been shown not to be wholly reliable for assessment of MHB hazards for some cargoes and IIMA therefore recommends caution.

For this reason, the "indirect approach" for determining critical limits for safe shipping of HBI in bulk as specified in the Direct Reduced Iron (A) schedule of the IMSBC Code continues to be the preferred approach for the HBI industry. This schedule defines the much simpler and more reliable measurable parameters of density ($>5,000 \text{ kg.m}^{-3}$), proportion of fines below 6.35 mm (maximum 5% by weight) and briquetting temperature ($>650^\circ\text{C}$). These limits reflect not only research by industry prior to the introduction of HBI as a commodity, but also the many subsequent years of experience with global shipment of HBI.

¹ <https://www.unece.org/fileadmin/DAM/trans/danger/publi/manual/Rev5/English/ST-SG-AC10-11-Rev5-EN.pdf>

Annex 1: Selected Definitions and Nomenclature²

Direct reduced iron - DRI

high grade feed for iron- and steel-making obtained from the reduction of natural or processed iron ores, without reaching the melting temperature.

NOTE: DRI includes metallized products that have been further processed by hot or cold briquetting.

Hot briquetted iron - HBI

direct reduced iron briquetted at a temperature greater than 650 °C and having an apparent density greater than 5 g/cm³

Physical testing - bulk density and apparent density

Bulk density

mass in air of a unit volume of particles of iron ore or direct reduced iron as aggregate, which includes the voids between and within the particles

NOTE 1: Bulk density is referred to as “pb” and expressed in kilograms per cubic metre.

NOTE 2: In industrial practice, the bulk density of iron ore or direct reduced iron is expressed as the ratio of the mass to the volume of a measuring container filled under specified conditions.

Apparent density

ratio of the mass in air of a particle of iron ore or hot briquetted iron to its apparent volume

NOTE: Apparent density is referred to as “pa” and expressed in grams per cubic centimetre.

Apparent volume

volume of iron ore or hot briquetted iron, including the volume of any closed and open pores

Open pores

voids within a particle connected with its outside environment

Closed pores

voids within a particle not connected with its outside environment

Water absorption

mass of water at a specified temperature that is absorbed into the open pores of dry hot briquetted iron

NOTE In ISO 15968, water absorption is referred to as a, expressed as a percentage of the dry mass.

Air-dried sample

sample whose moisture (6.29) is nearly equilibrated with the laboratory atmosphere

Oven-dried sample

sample that has been dried to constant mass at 105 °C in an oven

Tumble strength

resistance of lump ore, agglomerates or hot briquetted iron to size degradation by impact and abrasion, when subjected to tumbling in a rotating drum under specific conditions

NOTE: In ISO 3271 and ISO 15967, tumble strength is referred to as the tumble and abrasion indices:

² Reference ISO 11323 - Iron Ore and direct reduced iron - Vocabulary

- a) the tumble index is a relative measure of the resistance of lump ore, agglomerates or hot briquetted iron to size degradation by impact, referred to as "TI" and expressed as the percentage by mass of the +6,30 mm fraction generated in the test portion after tumbling;
- b) the abrasion index is a relative measure of the resistance of lump ore, agglomerates or hot briquetted iron to size degradation by abrasion, referred to as "AI" and expressed as the percentage by mass of the -500 µm fraction generated in the test portion after tumbling.

Degree of reduction

extent to which oxygen has been removed, under specific reduction conditions, from iron oxides, expressed as the ratio of oxygen removed by reduction to oxygen originally combined with iron

NOTE 1: ISO 7215, applicable to blast furnace feedstocks, determines for a reduction time of 3 h the degree of reduction referred to as the final degree of reduction (R180) expressed as a percentage by mass.

NOTE 2: ISO 11258, applicable to direct reduction feedstocks, determines for a reduction time of 90 min the degree of reduction referred to as the final degree of reduction (R90) expressed as a percentage by mass.

NOTE 3: The final degree of reduction is generally denoted by R_f.

Degree of metallization

relative measure of the amount of metallic iron (8.5) in the total iron content of direct reduced iron

NOTE 1: ISO 11257, applicable to direct reduction feedstocks, determines the degree of metallization, referred to as M, expressed as the ratio of the metallic iron (8.5) content at a reduction time of 300 min, to the total iron (8.6) content, as a percentage by mass.

NOTE 2: ISO 11258, applicable for direct reduction feedstocks, determines the degree of metallization referred to as MR, expressed as the ratio of the metallic iron content at a reduction time of 90 min, to the total iron content, as a percentage by mass.

Metallic iron

iron present in its non-oxidised state, with zero oxidation number

Total iron

all iron present in any form, free and combined with oxygen or other elements

*For more details and information refer to **ISO 11323 - Iron Ore and direct reduced iron - Vocabulary***

Disclaimer:

The information presented in this guide is intended as general information only and should not be relied upon in relation to any specific application. Those making use thereof or relying thereon assume all risks and liability arising from such use or reliance.